

Ø48 MANHOLE - WITH ECCENTRIC CONE

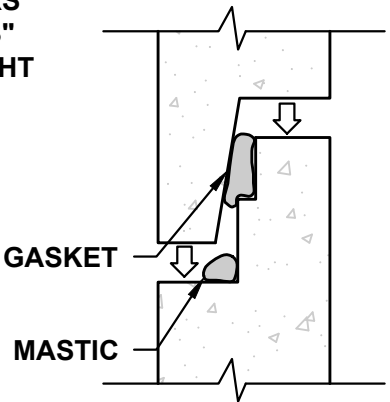

JOINT DETAIL

STANDARD JOINT SEALANT IS MASTIC. RUBBER GASKET IS OPTIONAL.

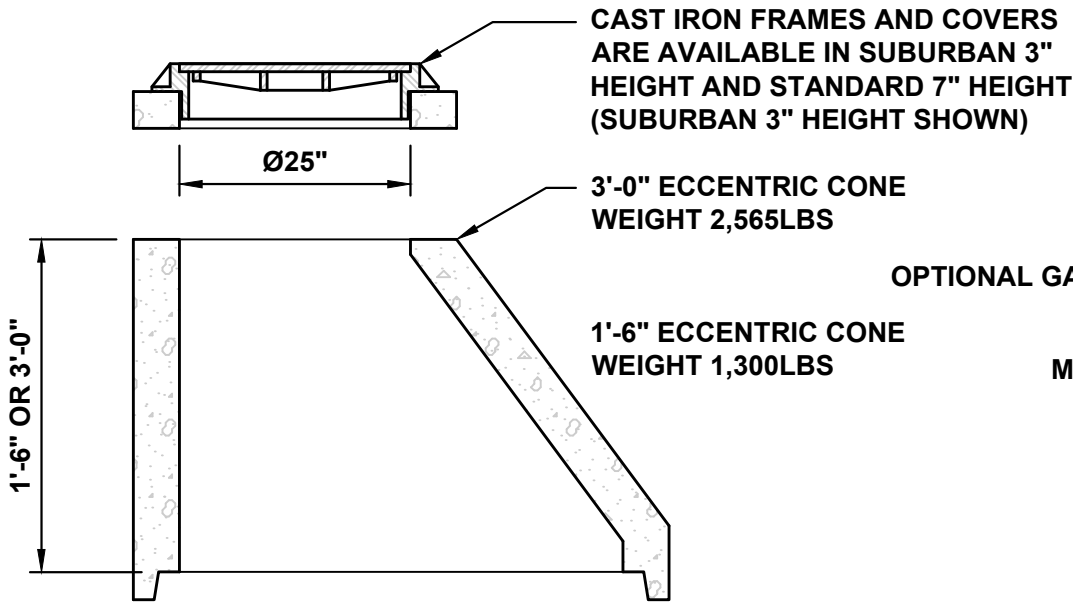
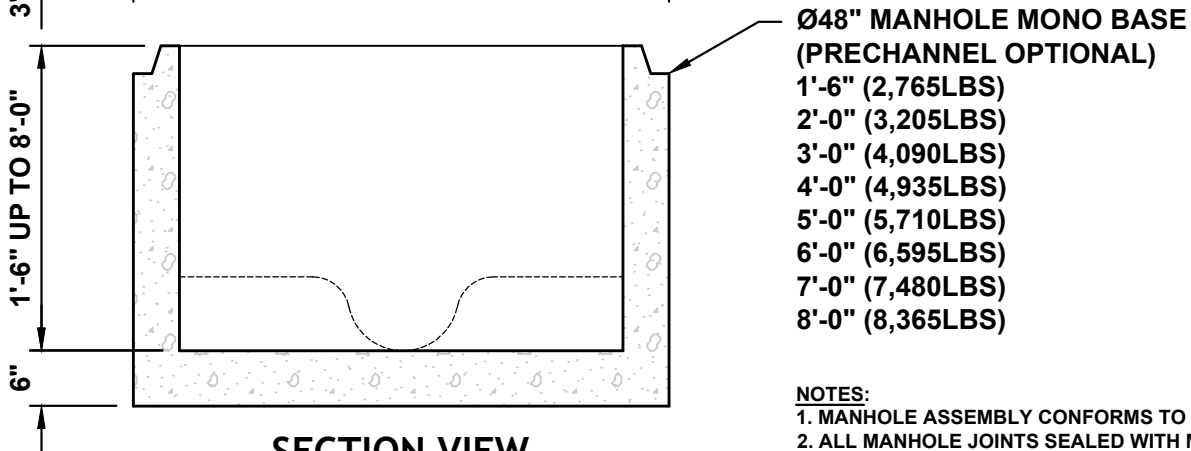
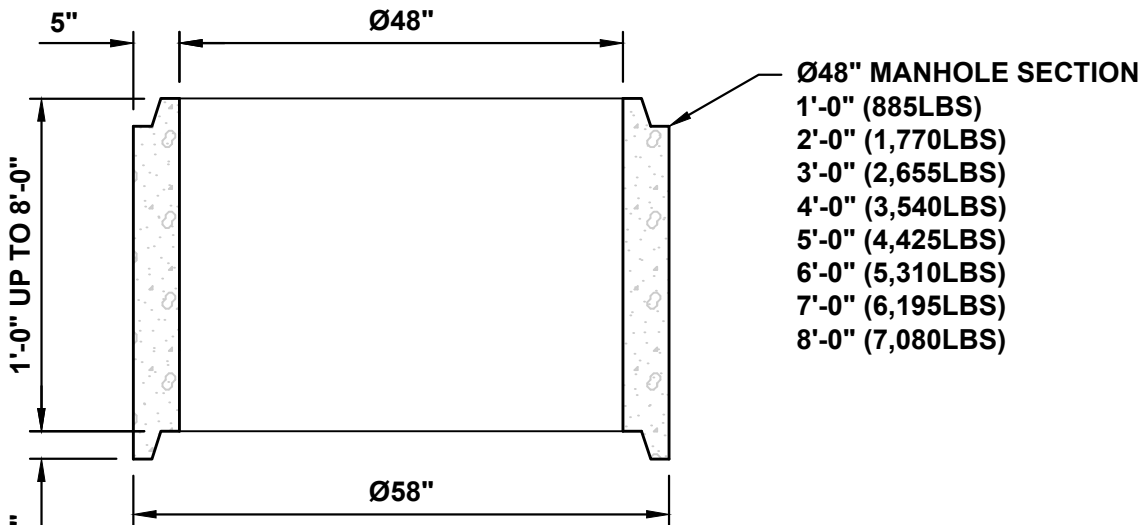

SECTION VIEW

NOTES:

1. MANHOLE ASSEMBLY CONFORMS TO ASTM-C478.
2. ALL MANHOLE JOINTS SEALED WITH MASTIC OR RUBBER GASKET.
3. WEIGHTS LISTED ARE APPROXIMATE.
4. GRADE RINGS AVAILABLE AS NEEDED.